

Assembly Instructions and Experiments

GOALS

- Understand why the vane points in the direction of the wind.
- Understand how the speed indicator works.

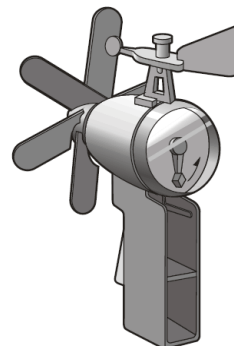

THINGS YOU WILL NEED

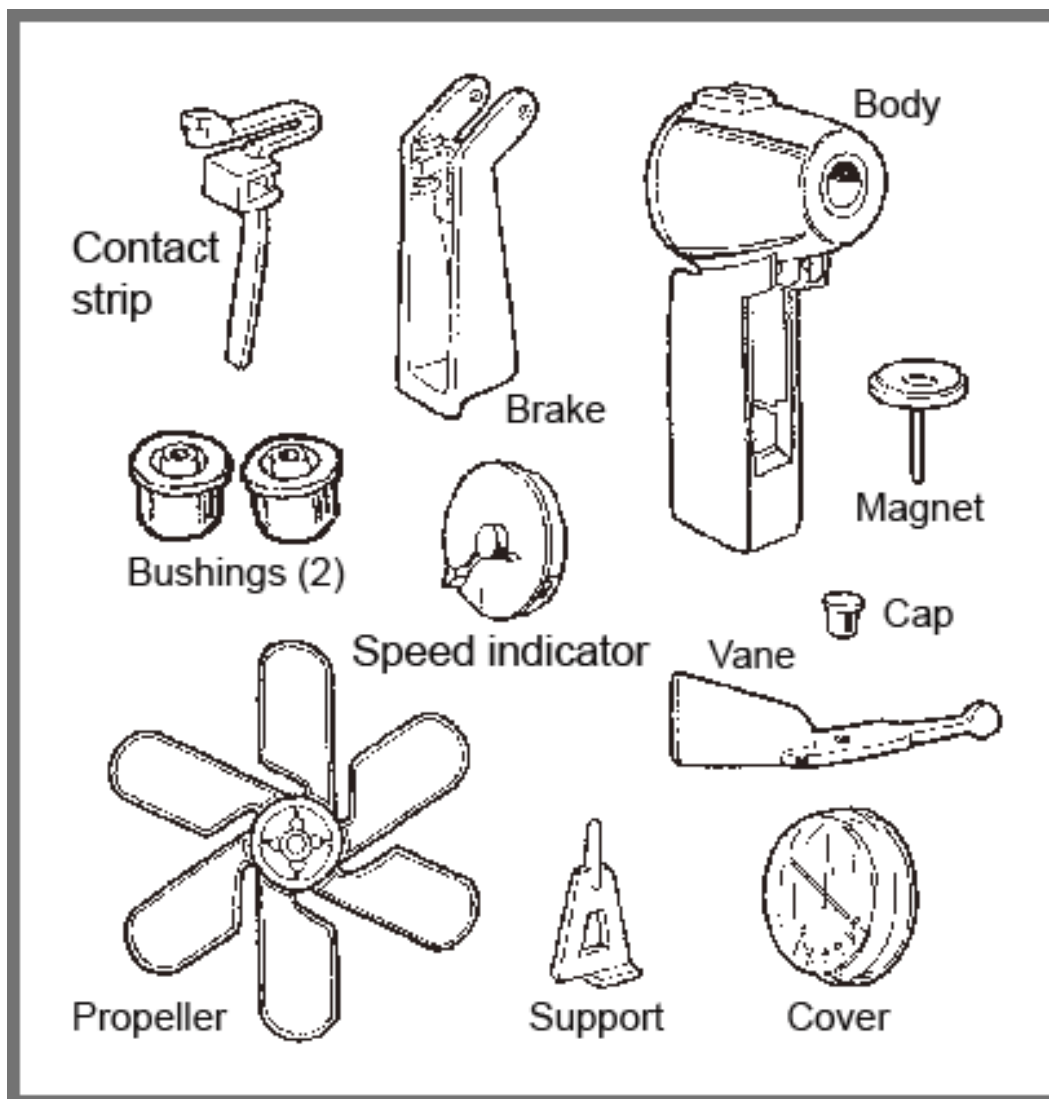

HOW TO ASSEMBLE

Step 1

Insert the contact strip into the brake.

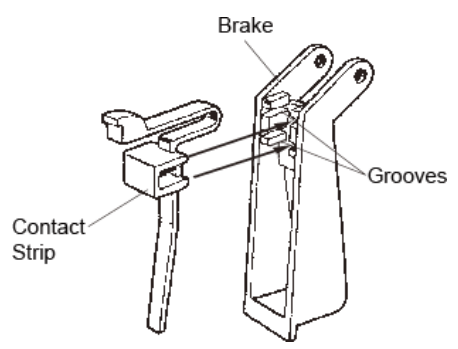

Step 2

Attach the brake to the body: Insert the bottom end first, and then push in the top until the pegs of the body slide into the holes. Use both hands to guide the brake into place.

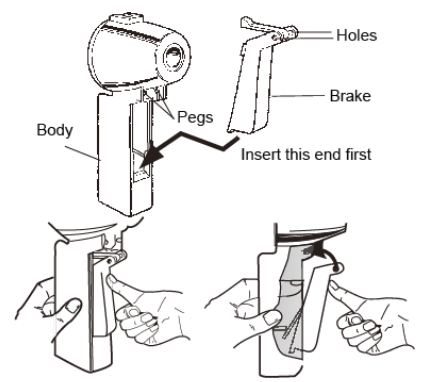

Step 3

Push the bushings into the body.

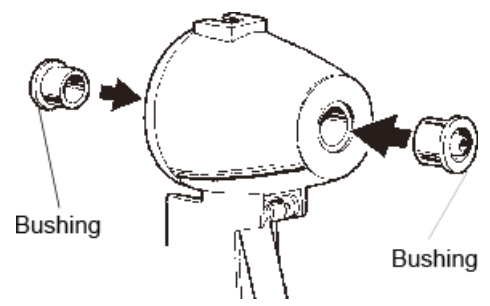

Step 4

Insert the shaft of the magnet through the bushings and into the propeller.

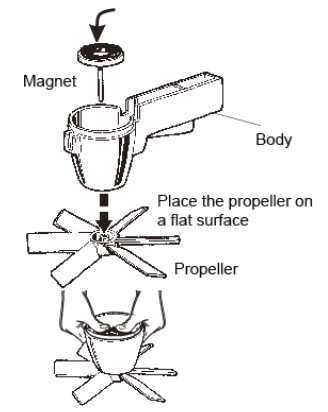

Adjust magnet:

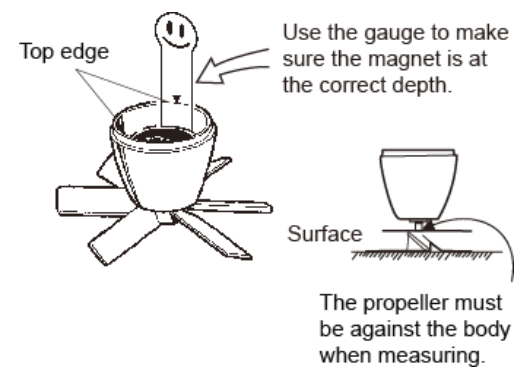

Gauge
(Cut along dotted line)

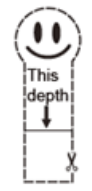

Step 5

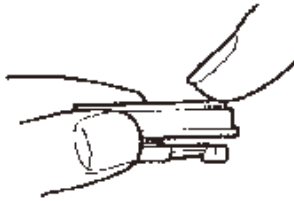
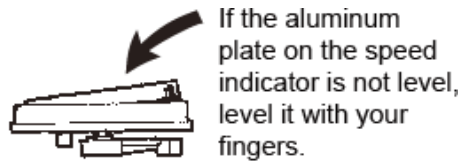

Insert the speed indicator

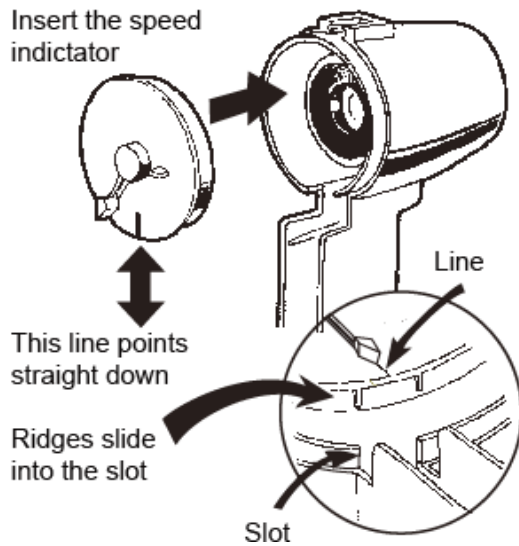

Step 6

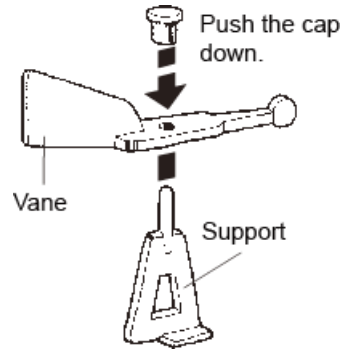

Step 7

Insert the assembled vane into the groove in the body.

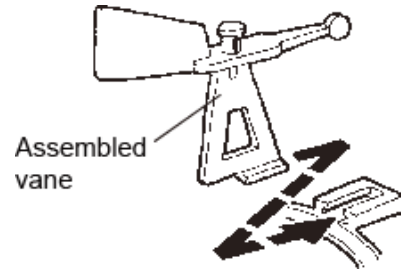

Step 8

Attach the cover to the speed indicator, making sure the 0 mark points straight down.

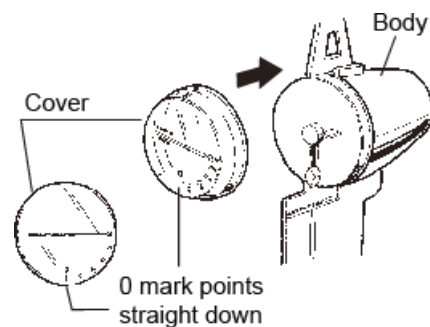

HOW TO OPERATE

You will need a strong wind for this to work.

1

Hold the indicator by the handle and point it into the wind. Do not press the brake.

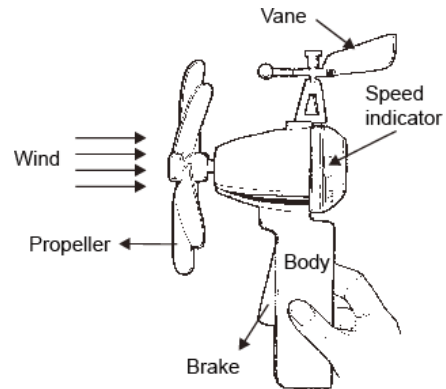

2

When the wind blows steadily, you will see the vane swivel and point into the wind. For example, if the wind is blowing from the east, then the vane will point to the east.

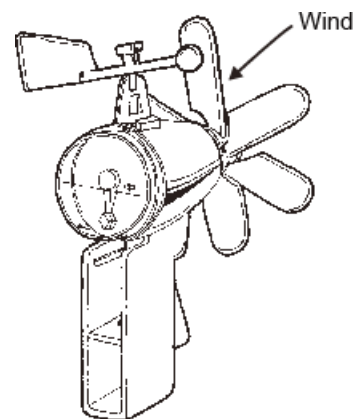

3

Face the wind and press the brake to lock the needle of the speed indicator in place. Read the wind speed shown by the indicator. Release the brake, and you will see that the needle can turn freely.

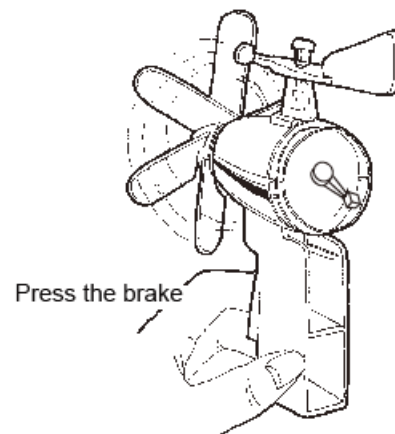

EXPLAINING THE CONCEPT

1
How wind direction is measured.

Wind exerts a force. The vane is designed so that the “moment of force” is greater on the tail than on the head, causing the head to turn into the wind. The vane rotates until the force of the wind on its surface is minimized.

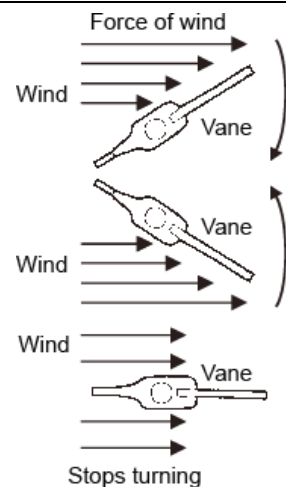
2
How wind speed is measured.

The wind causes the propeller to spin, in addition to the magnet which is connected to the propeller by the shaft. The spinning magnet causes the aluminum plate and its attached needle to rotate. The stronger the wind, the higher the needle will point.

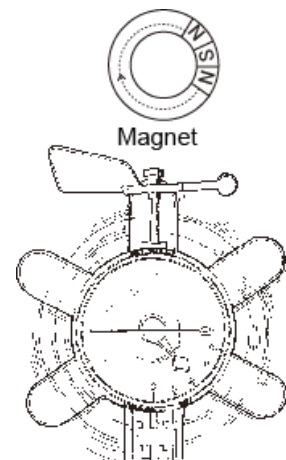

3
Why does the magnet cause the aluminum plate to rotate?

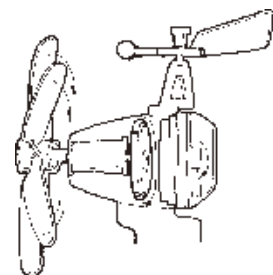
The concept is similar to an eddy-current speedometer. The aluminum plate is an electrical conductor. When the magnet spins near the plate, the changing magnetic field induces eddy currents in the plate. The eddy currents also produce magnetic fields. The result is that as the magnet spins, it creates a torque on the plate, dragging the plate and its attached needle in the same direction as the magnet. The torque on the plate increases with the rotational speed of the magnet, causing the plate to rotate further.

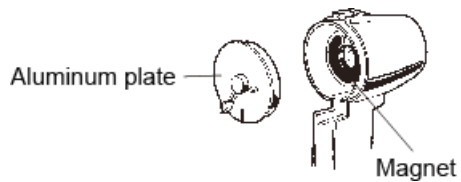

NOTES

1. Make sure the aluminum plate does not touch the magnet.



2. The propeller system must be assembled well to minimize friction and ensure that the speed indicator is accurate.



3. Do not press the brake until ready to measure the wind speed.

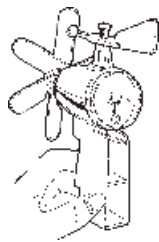

4. Make sure the contact strip of the brake can press against the aluminum plate and stop it from moving.

