

## Assembly Instructions and Experiments

### GOALS

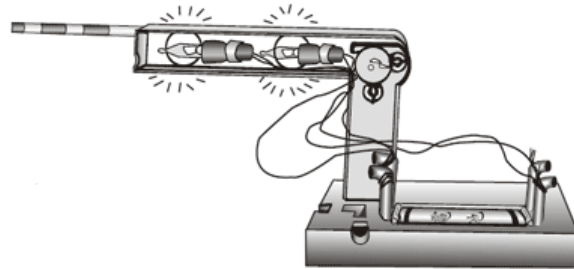



- Learn about circuits and electricity.
- Learn about the difference between parallel and series connections.

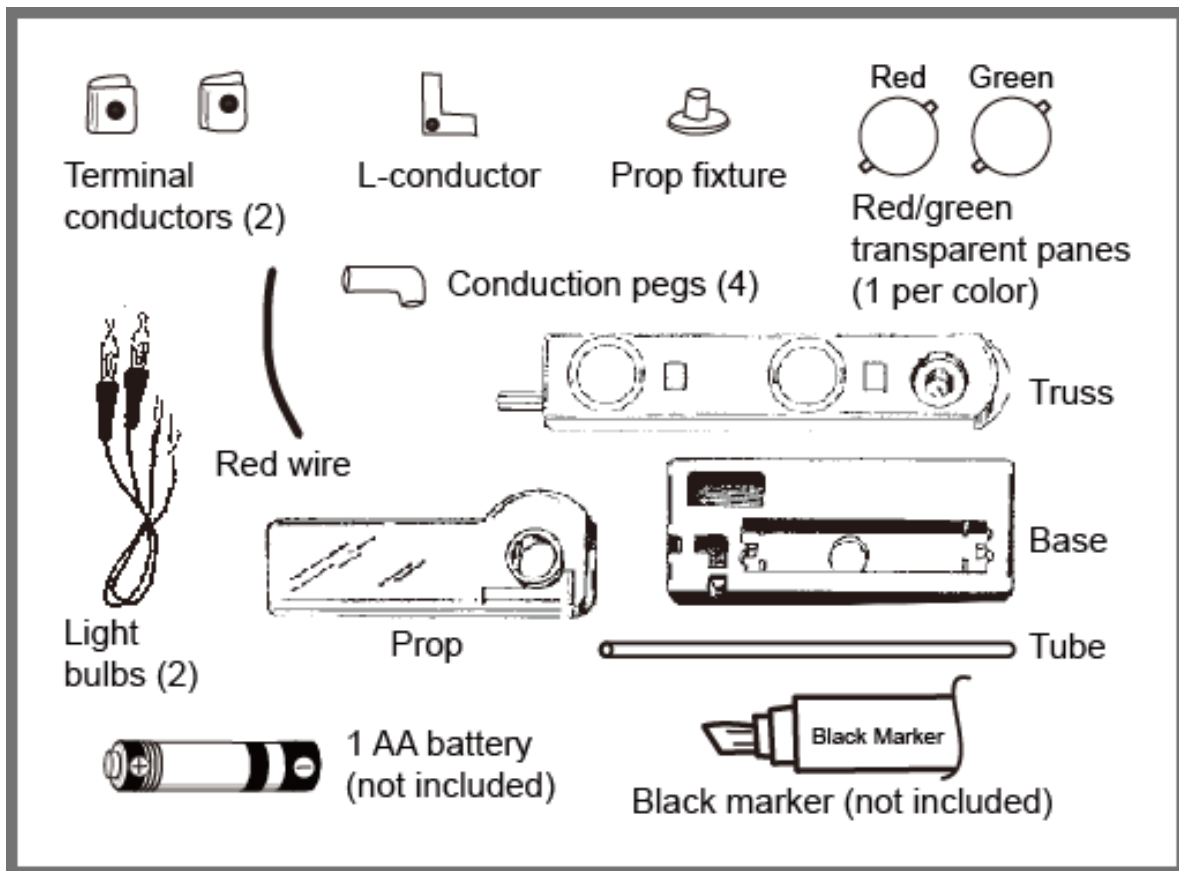

### THINGS YOU WILL NEED

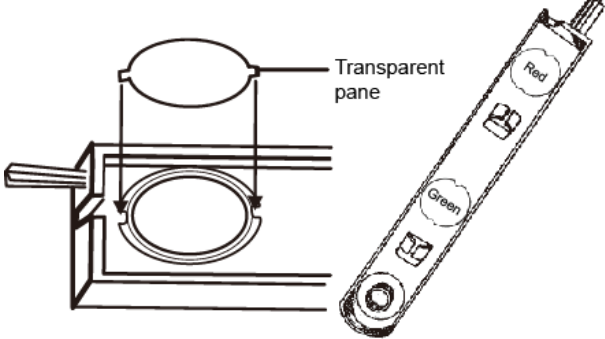

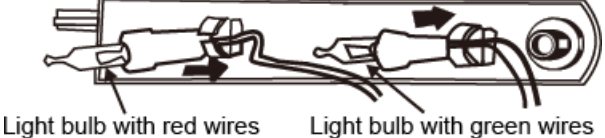
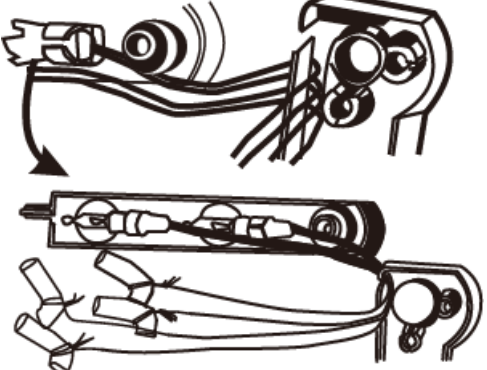
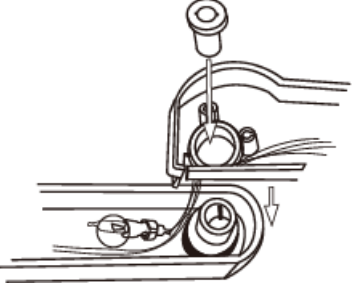
## HOW TO ASSEMBLE

|   |  |
|---|--|
| <p><b>Step 1</b></p> <p>Install the red and green transparent panes onto the truss as shown.</p>   | <p><b>Step 2</b></p> <p>Take a light bulb and wind the exposed end of each wire around a separate conduction peg. Repeat with the other light bulb and remaining conduction pegs.</p>  |
| <p><b>Step 3</b></p> <p>Insert each light bulb into its respective holder on the truss as shown.</p>   | <p><b>Step 4</b></p> <p>Pass the wires neatly through the gap in the prop as shown. Avoid tangling the wires.</p>   |
| <p><b>Step 5</b></p> <p>Insert the cylindrical protrusion of the truss into the hole in the prop as shown, and secure the pieces with the prop fixture.</p>  | <p><b>Step 6</b></p> <p>Connect one end of the loose red wire to the L-conductor, and the other end to a terminal conductor. Twist each end tightly on itself.</p>                   |

**Step 7**

Insert the longer leg of the L-conductor into the notched hole in the prop fixture.



**Step 8**

Insert the prop into the base. Attach both terminal conductors to the base as shown, making sure that the conductor attached to the wire is closer to the prop. Insert the battery as shown.

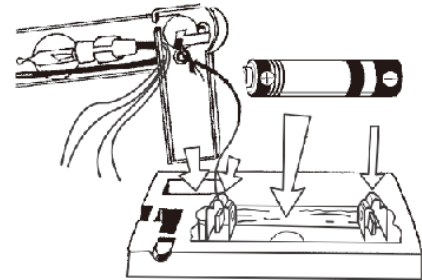

**Step 9**

Draw stripes on the tube using a black marker to make the tube look like a crossing barrier.



**Step 10**

Attach the tube to the front of the truss.

Insert a conduction peg connected to a red light bulb wire into the upper right hole in the prop.

Insert a conduction peg connected to a green light bulb wire into the lower hole in the prop.

Insert the remaining two conduction pegs into the base at the negative end of the battery in the positions shown.

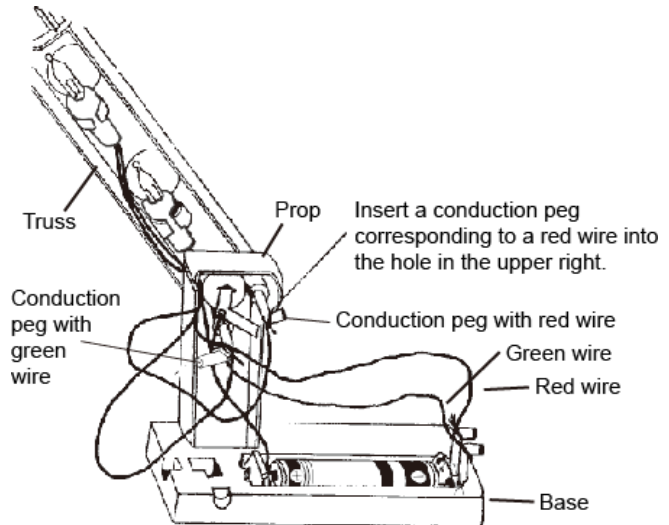

## HOW TO OPERATE

### 1 The switch (crossing barrier) mechanism:

● Red light only:

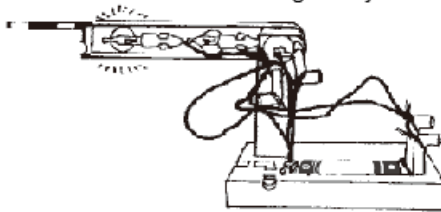

Lower the barrier to a horizontal position so that the L-conductor touches the conduction peg of the red wire. Only the red light will be on.

● Green light only:

The switch connects to the red wire.

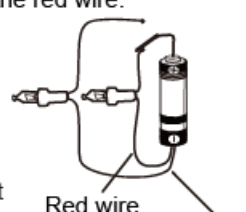

Red wire Green wire

Raise the barrier to a vertical position so that the L-conductor touches the conduction peg of the green wire. Only the green light will be on.

### 2 Light bulbs connected in parallel:

Pull out the conduction pegs that are inserted into the prop, and insert them into the base at the positive end of the battery in the positions shown. Both lights will be on, independent of the barrier position.

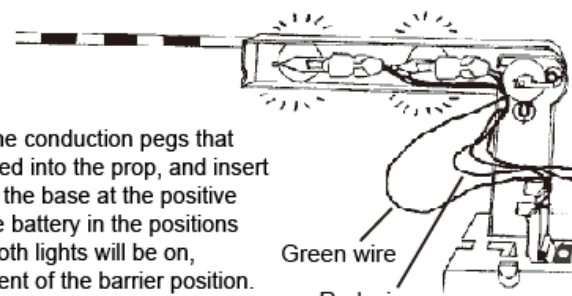

Green wire Red wire

● When the light bulbs are connected in parallel, the lights will be brighter, but the battery will deplete faster.

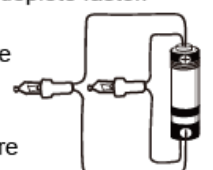

Red wire Green wire

### 3 Light bulbs connected in series:

Insert the conduction pegs into the base in the positions shown. Both lights will be on, but dimmer than before.

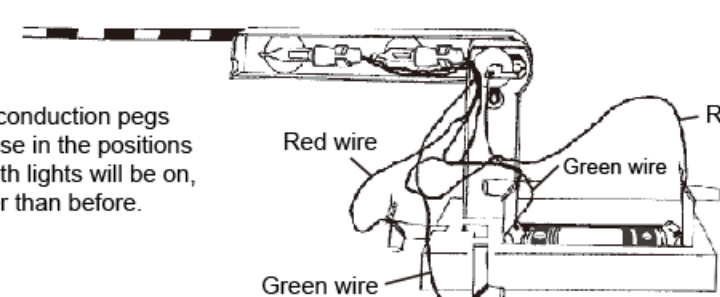

Red wire Green wire

● When the light bulbs are connected in series, the lights will be dimmer, but the battery will deplete slower.

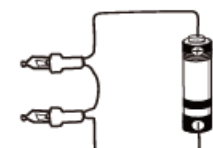

Red wire Green wire

**NOTES**



If the light bulbs do not turn on:

1. Make sure the wires are securely connected.
2. Make sure the terminal conductors contact the battery terminals, and the conduction pegs contact the terminal conductors where appropriate.
3. Make sure the battery is new.
4. Make sure the light bulbs work by touching the ends of the wires to the battery terminals.



5. When the barrier is in the raised and lowered positions, make sure the L-conductor touches the respective conduction peg.

**CAUTION**

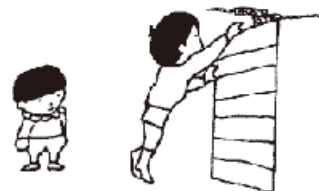
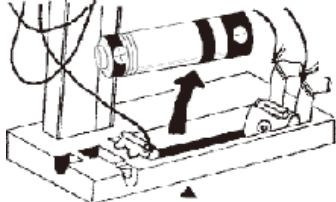
|  |  |
|--|--|
| <ul style="list-style-type: none"> <li>• Be careful not to crush the light bulbs when assembling.</li> </ul>   |  <ul style="list-style-type: none"> <li>• Do not pull too hard on the light bulb wire.</li> </ul>  |
| <ul style="list-style-type: none"> <li>• Do not insert wires into electric sockets.</li> </ul>    | <ul style="list-style-type: none"> <li>• When finished with the experiments, store the kit in a safe place out of the reach of young children.</li> </ul>                           |
| <ul style="list-style-type: none"> <li>• Do not forget to remove the battery when finished.</li> </ul>  <p>Insert your finger into the hole in the base underneath the battery to push the battery out.</p> |  |